

## Instruction Manual

Content

- Quick Start Guide** ..... 2
  - Scope of delivery ..... 2
  - Inspection for damage in transit..... 6
  - Available documentation ..... 7
  - Important notes ..... 8
- Setup and commissioning of the Agile Production Simulation**..... 9
  - Structure of the Agile Production Simulation ..... 9
  - Commissioning with a local application ..... 21
- Commissioning with fischertechnik Cloud**..... 31
  - 1. Connecting the router to an Internet connection..... 31
  - 2. registration in the fischertechnik Cloud..... 32
  - 3. coupling the APS with the fischertechnik Cloud ..... 32
  - 4. triggering the first order process via the cloud..... 33
- Programming tasks for PLC development** ..... 34
  - Task 1: Multiple milling ..... 35
  - Task 2: Extend OPC UA interface..... 35
- Technical documentation** ..... 36

# Quick Start Guide

Dear customer,

Thank you very much for choosing our product! This manual will guide you step by step through the commissioning, from reviewing the scope of delivery to placing an initial order for a workpiece in the **Agile Production Simulation** (referred to in the following as the APS) locally and over the fischertechnik Cloud. Please take a moment to read the instructions carefully.

## Scope of delivery

- Eight base plates with modules and track guidance

The different available modules are on six of these base plates; these are listed in the following section. There are also two track plates. These are connected between the modules using pins when setting up the APS, so as to create a surface on which the driverless transportation system (AGV) can move and transport workpieces.

The following section describes the six **modules** that are mounted on base plates, as well as the track plates:

1. Incoming / outgoing goods with 6-axis robot, Raspberry Pi 4B, WiFi router and sensor station

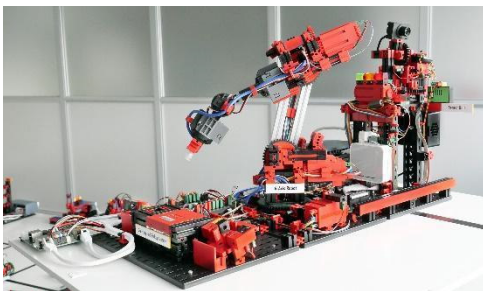

2. High-bay warehouse

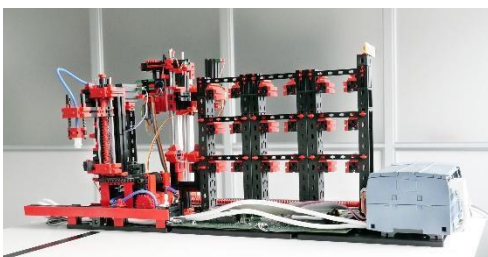

### 3. Drilling station

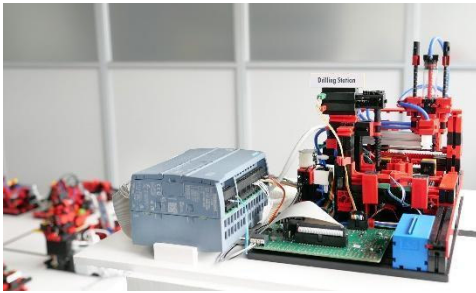

### 4. Milling station

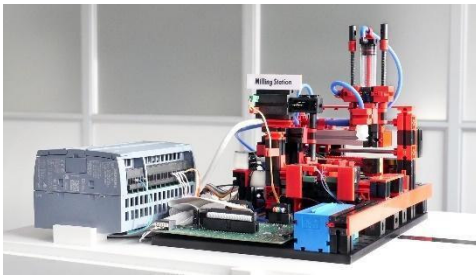

### 5. Quality assurance with AI



### 6. Charging station

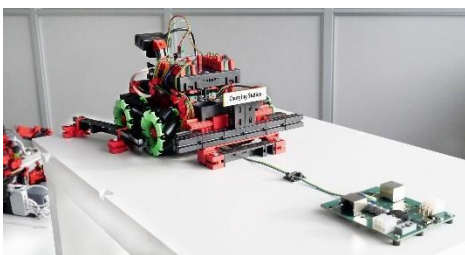

### 7. Two track plates

The AGV moves on these plates.



- A **AGV** (Automated Guided Vehicle)  
This system moves on the base plates and is responsible for transporting the workpieces between the modules. In contrast to the modules, the AGV is supplied with power by a battery

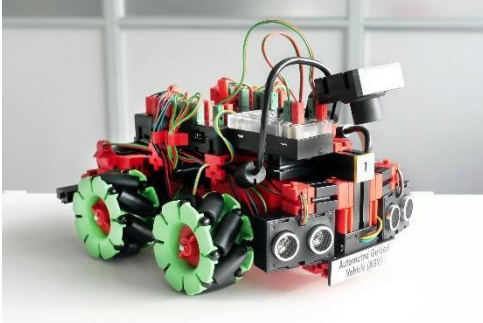

- (Optional) two **carrying cases** for transporting and storing the base plates and modules, the lane plates and the AGV



- A **24V power supply 11A**  
For supplying power to the modules.



- **A 9V charger**  
For supplying the charging station with the charging voltage for the battery of the AGV.



- **Additional accessories**
  - Nine empty workpiece carriers for the high-bay warehouse and three empty workpiece carriers for the AGV.



- 24 workpieces in the three available colors red, white and blue. Stickers are already attached to the workpieces, which will be analyzed in the quality assurance.



- Five Ethernet cables to connect the module plates together.



- Six power cables to connect the module plates together.

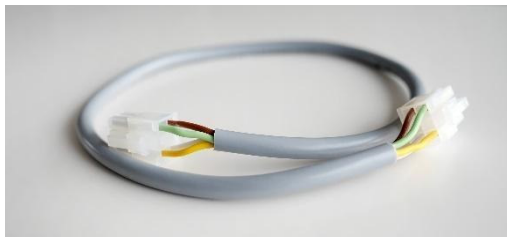

## Inspection for damage in transit

After you have carefully removed the AGV from its packaging, complete a visual inspection to determine whether components have come loose or been damaged during transit. The following section provides instructions for how to inspect the system for damage sustained in transit, and what to do if you find damage.

Box:

inspect the outer box for visible damage such as dents, holes or tears.

Loose parts:

Check whether loose parts are lying inside the box that may have come loose during transportation. If necessary, return loose components to the correct positions.

Loose cables:

Inspect all included cables for damage and check to ensure they are attached securely. Check to ensure all hoses are connected.

### Documenting damage:

- Take photographs of all damage found.
- Note down details like the type and scope of damage.
- Contact customer service:

**Report damages found** promptly to our service department. Send photos and your notes regarding the damage as an attachment to your email.

fischertechnik GmbH

Klaus-Fischer-Str. 1

72178 Waldachtal

Germany

Phone: +49 74 43/12-43 69

Fax: +49 74 43/12-45 91

info@fischertechnik.de

www.fischertechnik.de

## Storing the **packaging**

- Store all packaging materials and damaged parts until your case has been clarified.
- If you find serious damage, do not operate the product, in order to avoid further damages.

Please pardon us for any inconvenience – we will do everything in our power to replace or repair damaged or faulty parts as quickly as possible. If you have questions regarding the inspection for damage in transit, or if you need support, our customer service department will be happy to assist you at any time.

## **Available documentation**

We provide you with extensive documentation to make it as easy and convenient as possible for you to get started with and use the APS. This documentation helps familiarize you with the product, clarify any questions which may come up, and support you in commissioning and operation.

The documentation components are available online in different formats, and are updated regularly to ensure you always have access to the latest information and instructions. This allows you to access the documents you need anytime and from anywhere, and thereby get the most out of your system.

The documentation available online covers:

- Setup and commissioning of the Agile Production Simulation
- Commissioning the Agile Production Simulation with the fischertechnik Cloud
- Technical product details
- Calibrating the Agile Production Simulation
- Programming tasks for PLC development



The corresponding documents are available in different languages at the following link:

<https://www.fischertechnik.de/e-learning/agile-production-simulation>



We recommend familiarizing yourself with the available documentation in order to ensure a smooth commissioning process and fault-free operation. If you have further questions or need specific information, do not delay to contact our customer service department.

### **Important notes**

- Please store this manual for later reference.
- Switch off the system when it is not in use in order to save energy and extend the service lives of your components.

We wish you much success with the Agile Product Simulation! If you have questions or concerns, our customer service department would be happy to assist you.

# Setup and commissioning of the Agile Production Simulation

Supporting you right from the start is important to us – from the moment you open your product, to the moment you successfully produce your first workpiece.

With this “Setup and commissioning” documentation, we want to provide you with a clear and easy to understand guide. Step by step, we will go through all necessary processes and actions together, in order to ensure your product is set up optimally.

## Structure of the Agile Production Simulation

Before we move on to the actual commissioning of your system, we will begin with the essential step of physical setup. This includes, in particular, connecting and combining the base plates and carefully wiring them together.

In a successful setup, all of the plates in the APS are securely connected to one another. When the programs start on the individual modules, this indicates that this process is complete. Only when they run smoothly can we be certain that the physical setup was completed correctly and in full.

### 1. Physically connecting base plates

We recommend positioning the base plates according to the enclosed layout so that your system is ready to use directly and without additional configuration. Ensure that all modules are placed correctly.

You can tell they are positioned correctly because all tracks will either end on the modules or have open ends intended for potential expansion of the APS. The base area on which the AGV travels must be flat. We recommend setting up the entire system on a flat surface like a large table. A flat surface of at least 184 cm x 129 cm is required for the AGV set up according to the following layout.

The standard setup is shown in the following layout. The plates are each connected physically by pins, to that they fit together like puzzle pieces and cannot slide apart.

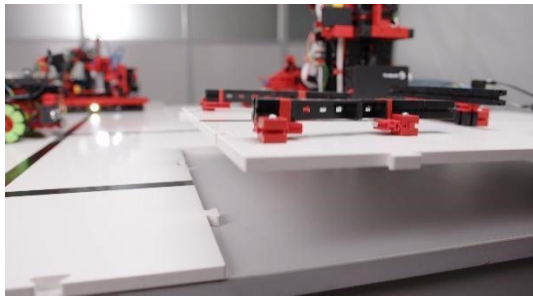

## 2. Electrically connecting base plates

The goal is to connect each base plate with the enclosed power and Ethernet cables. Both the power and network connections are looped through the modules. Ensure that you do not complete the wiring in a circuit.

Start with the power connection of the 24 V power supply to the charging station's connection board. You can temporarily plug the 24 V power supply into the outlet in order to test the connection board. The green LED on the connection board indicates that the 24 V power supply was connected successfully.

Before continuing with the next steps, **disconnect the 24 V power supply once again** as a safety measure, to ensure that it is not connected to power when wiring the modules.

Connect the 9 V power supply (charger) to the charging module. Then you can connect the Ethernet cable and power cable to the connection board. These are used to connect the connection boards with the other modules.

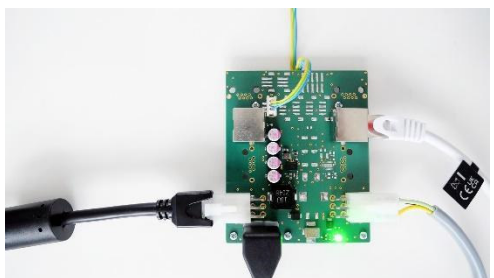
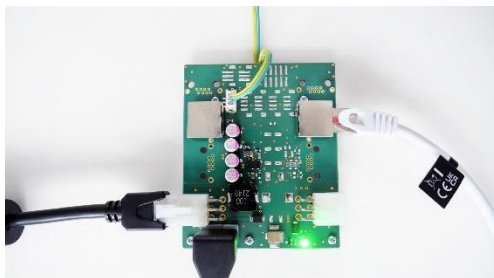
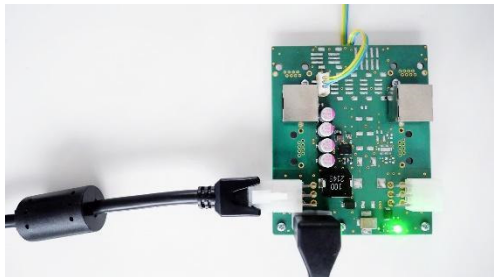
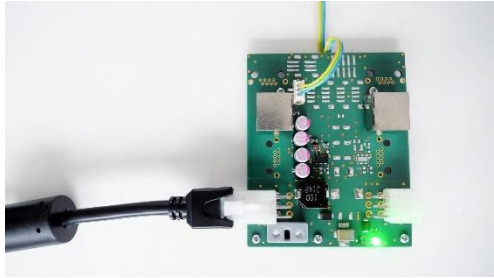
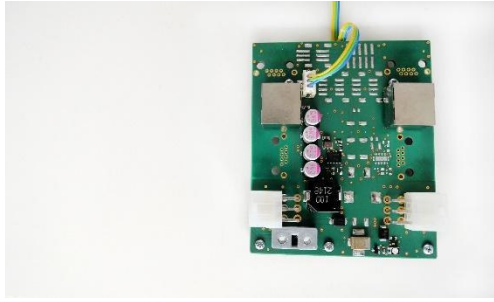

Ensure that all cables are securely connected to the connection boards. Then plug the 24 V power supply and 9 V power supply into an outlet and use the following description with LED 1 and LED 2 to ensure the modules are supplied correctly with power.

LED1 on the connection boards of the other modules indicates the power supply status:

- Green means that the 24V power supply is connected successfully.
- Red means that it is connected with reverse polarity.

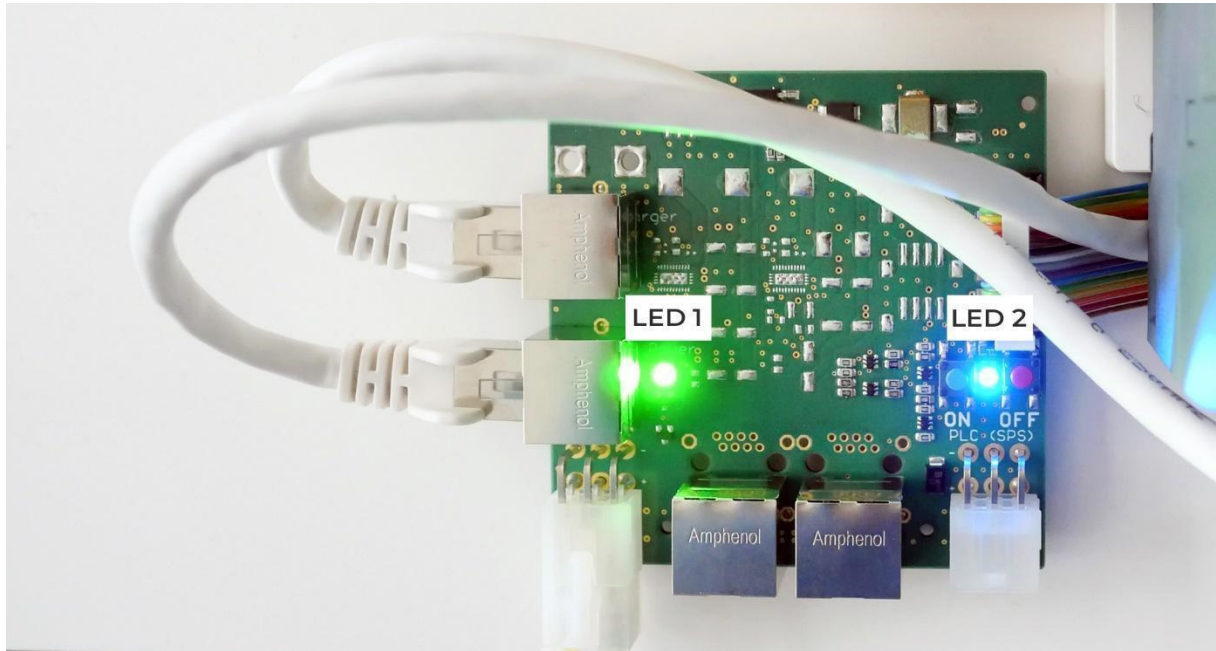

In addition, there are two buttons with LED 2 on each connection board to the power supply. These are used as an emergency stop for the individual module.

- LED 2 will be illuminated blue when the power supply has been completed successfully.
- Red button: Triggers the emergency stop, interrupts the power supply to the PLC and LED 2 is illuminated red.
- Blue button: The blue button must be pressed to restore the power supply. LED 2 will be illuminated blue once again.

The following is an image showing what the connection board looks like when it is fully connected.



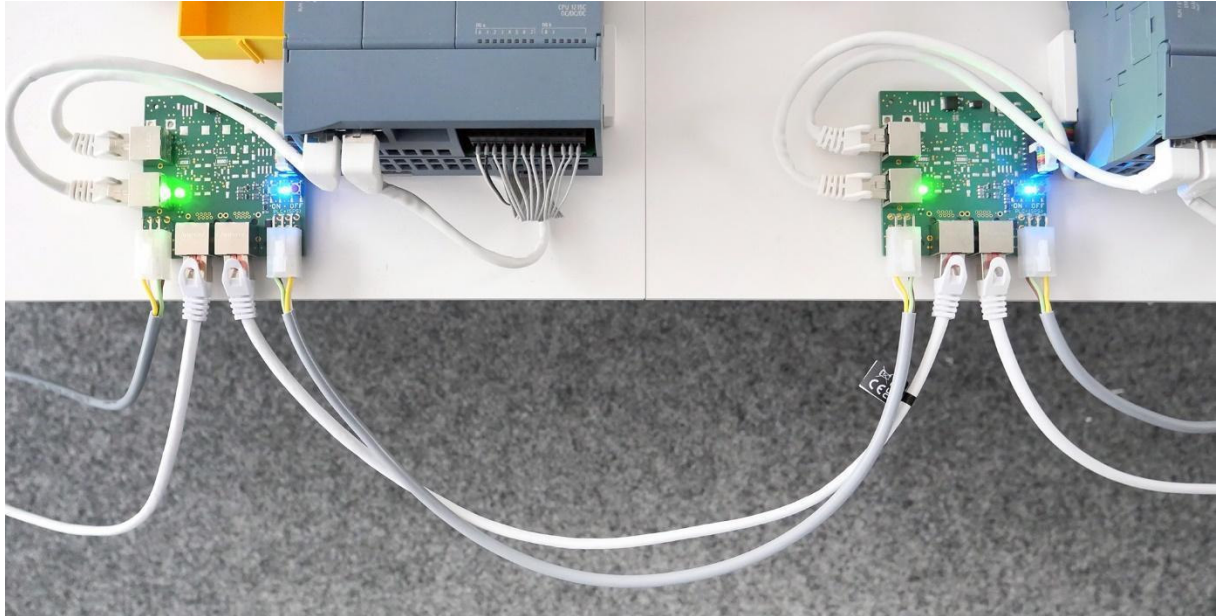

All modules, the router and Raspberry Pi will start up automatically when the power supply is active; the necessary programs are pre-installed.

When the power supply is complete, the status LEDs will be illuminated on the top of the PLC. On the TXT 4.0 controllers, the screen will be illuminated and show the start screen.

The following is an overall image of the APS as it looks when it is wired fully.

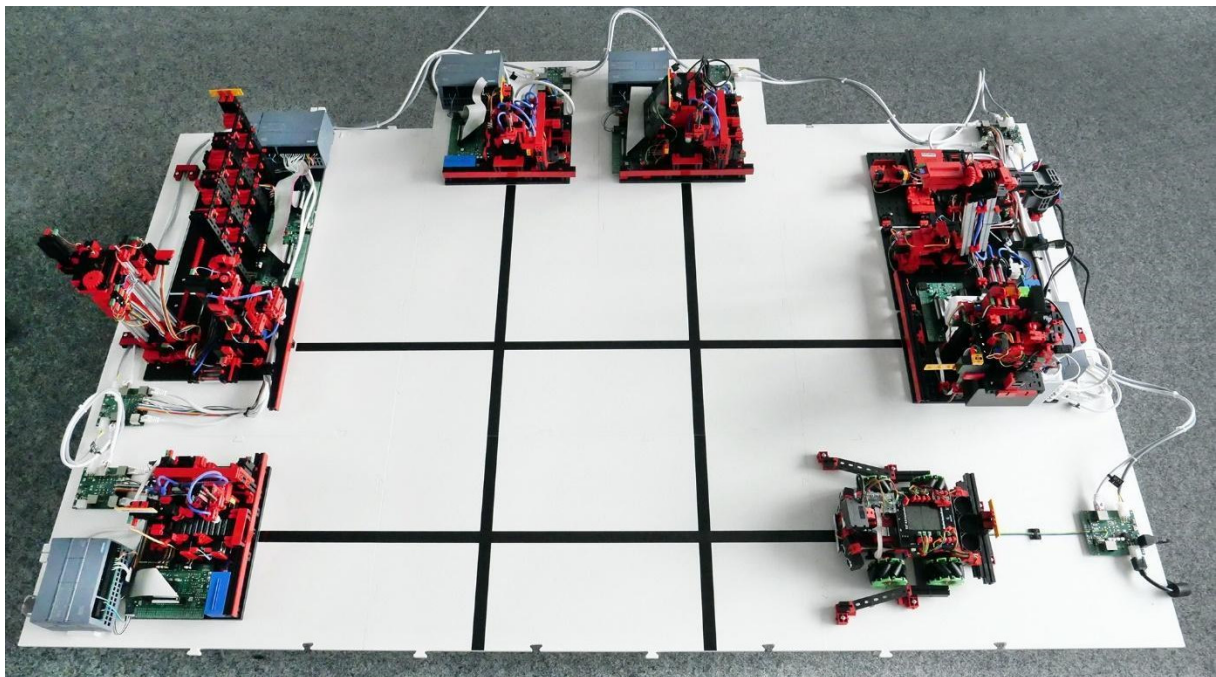

This setup is saved in the central controller as the standard layout, and is also mapped digitally in the application.

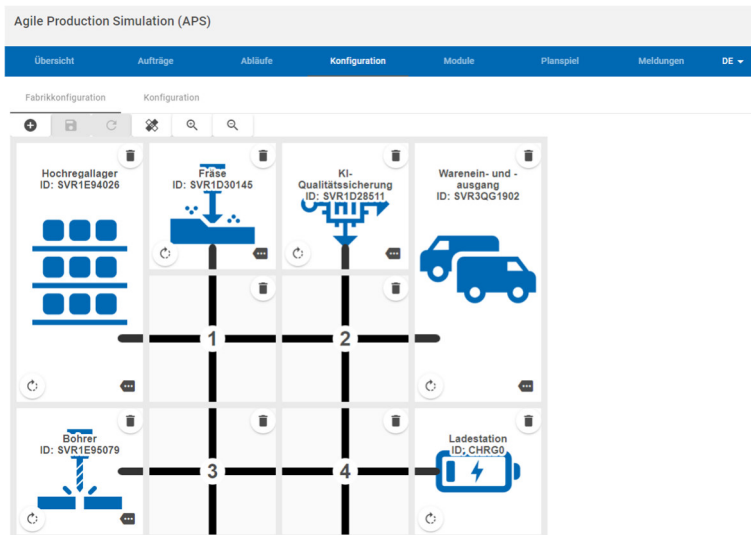

### 3. Check the start-up of module applications

Most digital components of the APS will start automatically once the power supply has been completed:

- The pre-installed PLC programs.
- All programs on the Raspberry Pi, in particular the central APS controller.
- The router to setup the wireless network.

If a program must be manually restarted, this can be triggered by interrupting and then restoring the power supply.

The programs are already pre-selected on all four TXT 4.0 controllers and can be started by pressing the touch screen.

After a successful start:

- A module-specific interface will be visible on the TXT 4.0 controllers. The program can be ended by pressing “Stop program” on the bottom edge of the screen. The green indicator beside “CONNECTED” indicates that the

controller is connected to the central control unit.



- The status LED beside the “RUN/STOP” lettering on each PLC is green.

Before continuing with setup of the AGV, place the included black workpiece carrier into the high-bay warehouse. The high-bay warehouse has a total of nine storage spaces for it. Ensure that the groove points forward, so the workpiece carrier can be removed and placed inside reliably by the robot.

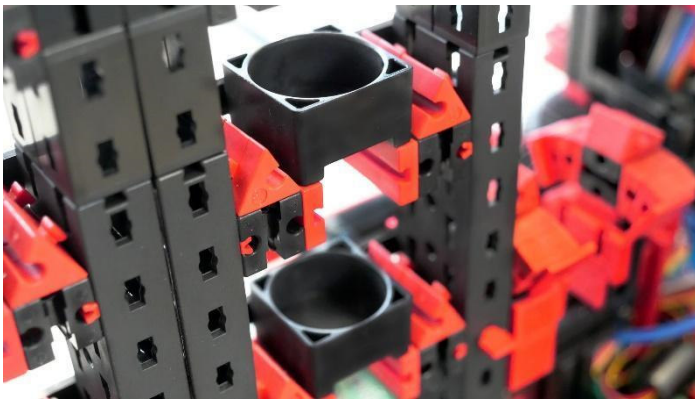

#### 4. Start the Automated Guided Vehicle (AGV)

The AGV also has three storage spaces for workpieces. As in the high bay warehouse, three workpiece carriers must also be inserted there so that the workpieces can be transported securely.





The power supply for the AGV is provided by the fischertechnik battery included in the scope of delivery. It is delivered already charged up, so you can start the AGV directly.

The AGV can be started by pressing the "ON/OFF" button. As with the modules, the AGV also loads the right program automatically and can be started using the touch screen.

If the battery charge status is too low to start the program, you can also charge it with the APS charging station or directly via the enclosed 9 V charger.

1. With the charging station of the APS:

Please note that the APS must not be in operation. The charger must be plugged into the charging station and into a socket. The circuit board in the charging station must be connected to 24V and the 24V power supply unit must also be connected to the socket. If the TXT 4.0 on the AGV is still on, switch it off via "ON/OFF". Place the AGV in the charging station of the APS by hand so that the charging contacts are connected to the contacts on the AGV. The battery is charged when the red LED on the 9V charger and the LED in the charging electronics on the AGV flash. When the battery is fully charged, the red LED on the 9V charger stops flashing and lights up continuously.

2. With the 9 V charger:

To do so, you must remove the battery from the AGV and connect the charging cable directly.

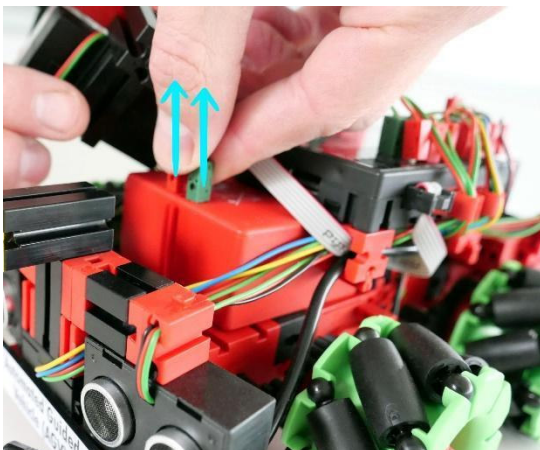
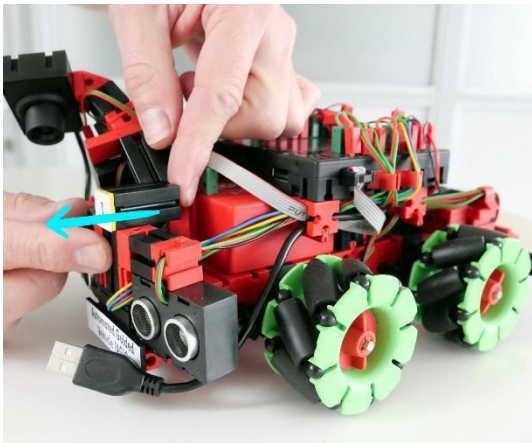
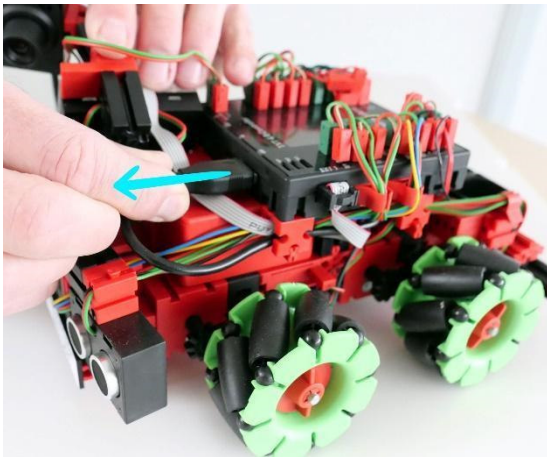
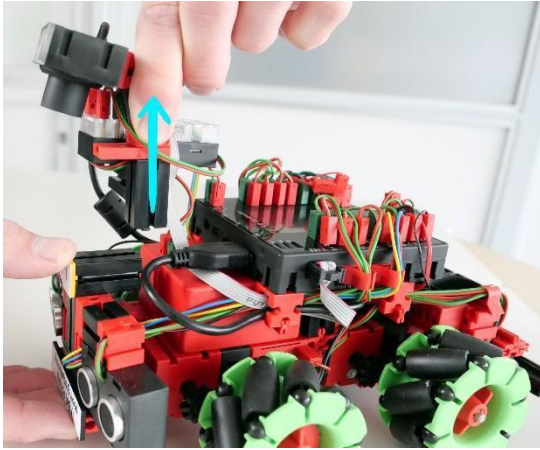

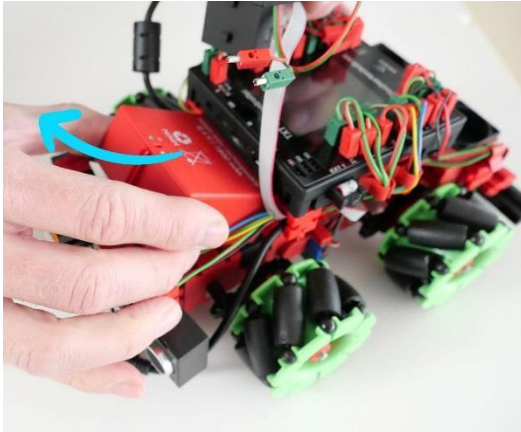

When the battery is fully charged, the red LED on the 9V charger stops flashing and lights up continuously.

## 5. Starting the user interface for control and configuration

Once the incoming/outgoing goods module is supplied with power, the Raspberry Pi placed there that handles central control of the APS also starts up. The router that sets up the entire network of the SPS is also located there. No internet connection is required for initial commissioning of the APS. The connection to the fischertechnik Cloud is described separately in the "Commissioning with the fischertechnik Cloud" section.

The central controller consists of a server component that runs in the background. It monitors and controls all states of the entire APS. The central controller also offers a user interface with which you can interact.

To access the user interface, you must connect to the router network (WiFi) using a browser-capable device of your choice (such as a laptop or a tablet). The name of

the network (SSID) and password generated for your APS are shown on the side of the incoming / outgoing goods sensor station.

Once you are successfully connected to the network, access the address 192.168.0.100 in your browser. The following interface will load (<http://192.168.0.100>). This interface contains all of the functions available for operating, monitoring, and configuring the APS.

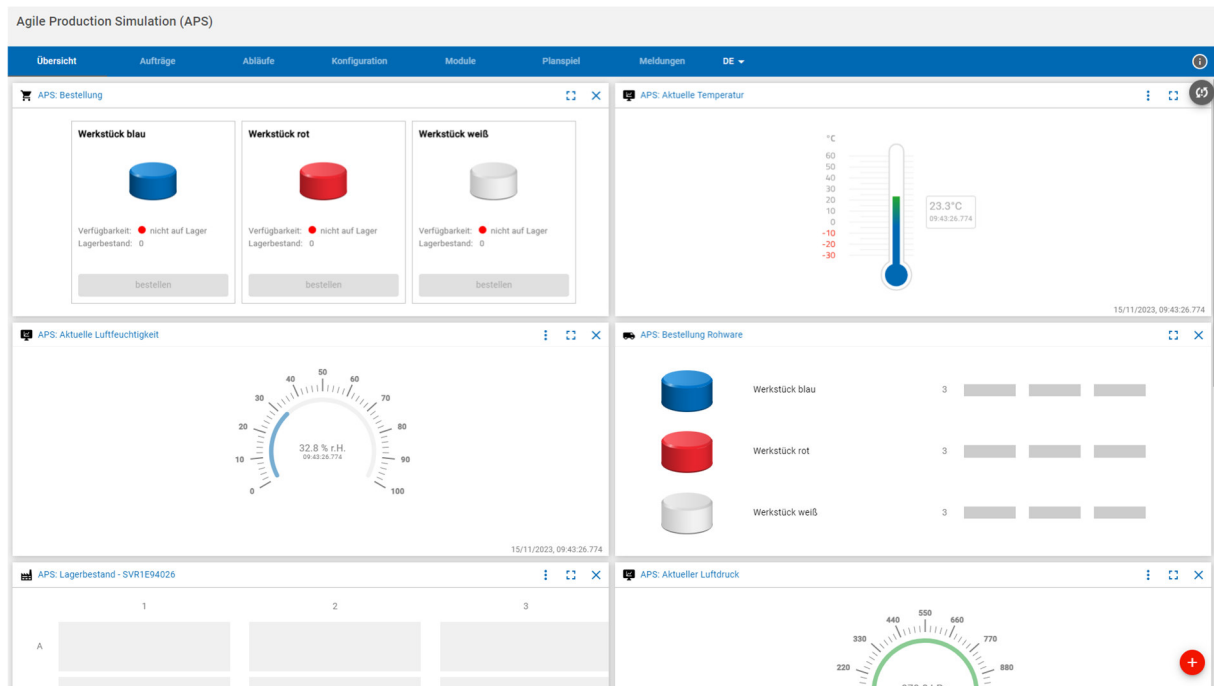

Click “Module” to navigate to the module overview.

The setup was successful if all six modules on the base plate and the AGV are displayed in the list. The “Connected” column shows the current connection status between the respective module and central controller.

Agile Production Simulation (APS)

Übersicht   Aufträge   Abläufe   Konfiguration   **Module**   Planspiel   Meldungen   DE

**Moduleübersicht**

ID	Name	Verbunden	Konfiguriert
SVR1D30145	Fräse	📶	🔧
SVR1E95079	Bohrer	📶	🔧
SVR1D28511	KI-Qualitätssicherung	📶	🔧 <input type="button" value="Kalibrieren"/>
SVR1E94026	Hochregallager	📶	🔧 <input type="button" value="Kalibrieren"/>
SVR1D26982	Warein- und -ausgang	📶	🔧 <input type="button" value="Kalibrieren"/>
CHRGO	Ladestation	📶	🔧
zgb2	Fahrerloses Transportsystem	📶	<input type="button" value="Docke an DPS"/>

All modules are set up and networked. In the following section “Commissioning with a local application,” the configuration is checked and the APS is set to active, so that the first workpiece can be stored and produced. As described in the next section, the Reset button at the top right of the interface is the best way to correct initial connection problems.

## Commissioning with a local application

After the physical setup has been completed successfully, there are some final steps to complete. Commissioning of the APS includes the configuration, and concrete instructions for how to produce a workpiece.

### 1. Check the module connection status

Navigate to the “Module” menu. A list of connected modules will appear. All six products included in the scope of delivery will be listed. The icon in the “Connected” column indicates whether an active connection has been completed between the central controller and corresponding module. If a module is not shown as connected, the following actions may be helpful:



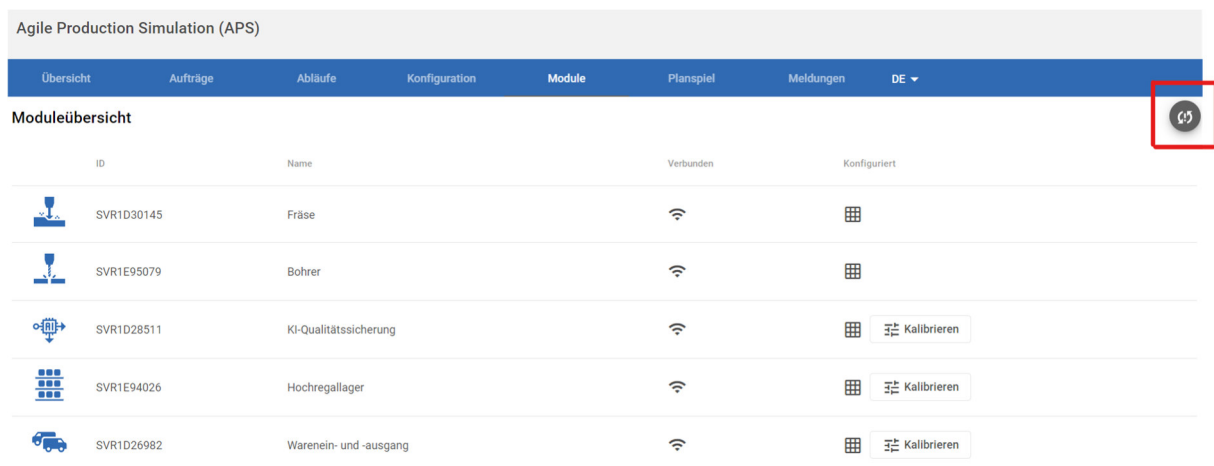

- Check the wiring of the module and correct accordingly if a power or network cable has come loose.
- **Resetting the APS:** The “Reset” button is always at the top right of the user interface (see the screen shot) and resets the APS to its initial state. This means that all active orders will be removed and the connections between the central controller and all modules will be newly formed. The stock in the high-bay warehouse can also optionally be reset if there are any problems (for instance, if a workpiece is lost).



Agile Production Simulation (APS)

Übersicht   Aufträge   Abläufe   Konfiguration   **Module**   Planspiel   Meldungen   DE ▾

Moduleübersicht

ID	Name	Verbunden	Konfiguriert
 SVR1D30145	Fräse	📶	📶
 SVR1E95079	Bohrer	📶	📶
 SVR1D28511	KI-Qualitätssicherung	📶	📶 <input type="button" value="Kalibrieren"/>
 SVR1E94026	Hochregallager	📶	📶 <input type="button" value="Kalibrieren"/>
 SVR1D26982	Warenein- und -ausgang	📶	📶 <input type="button" value="Kalibrieren"/>

This view also offers the possibility of calibrating modules. Module-specific positions and distances are set in this process. The APS is delivered pre-calibrated; however, the modules may be moved during setup and disassembly. If a module no longer grips the workpiece precisely, you can correct this via the calibration. Instructions for doing so are found at the following [link](https://www.fischertechnik.de/e-learning/agile-production-simulation):

<https://www.fischertechnik.de/e-learning/agile-production-simulation>

### 2. Check the layout of the module

The APS is pre-configured and delivered with a standard layout. The layout of the APS defines where each module is located, and is the digital representation of the physical structure. The user interface is located under the “Configuration” menu item.

The standard layout can be maintained for commissioning. Check once again to ensure you have arranged all modules correctly, so that all tracks and modules are correctly arranged.

You can experiment with different layouts as you continue using the modules, by rearranging them via drag & drop and saving the changes, so that the digital map reflects the physical placement of the modules. This function is blocked if there is an active production order in the APS. The previously mentioned Reset button can be used to reset the APS to the initial state and make changes to the configuration.

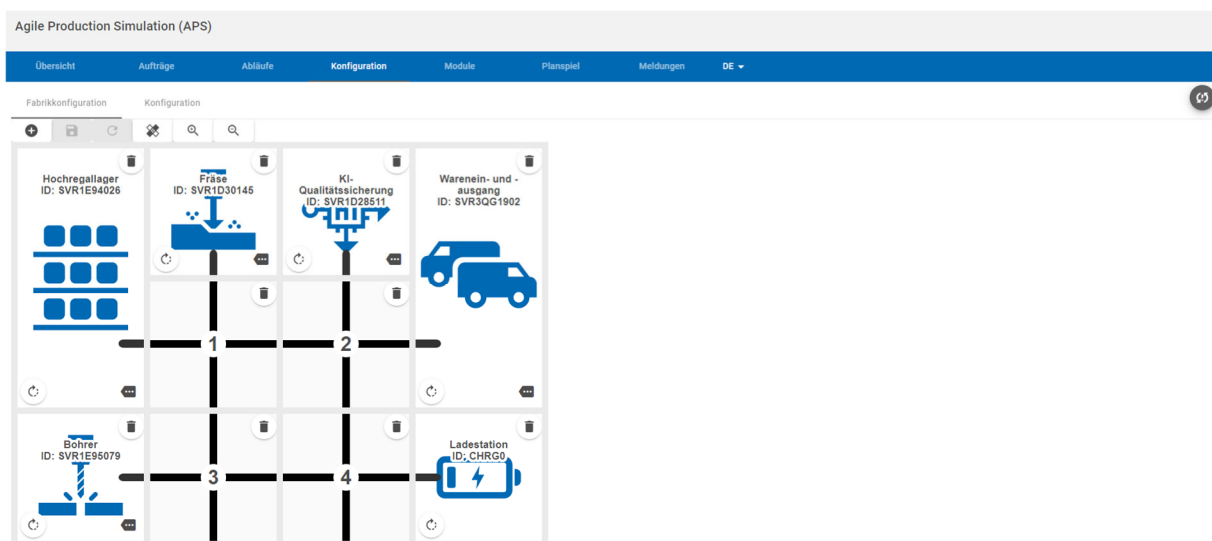

### 3. Defining production processes for the three different workpieces

The production steps necessary to process the workpieces can be configured individually depending on their color.

Each color has a mandatory processing station (drilling and/or milling) and optional stations like AI quality assurance.

The default settings can be maintained for commissioning. Here as well, you can make changes to the APS via drag & drop without programming knowledge, similar to reconfiguring the layout.



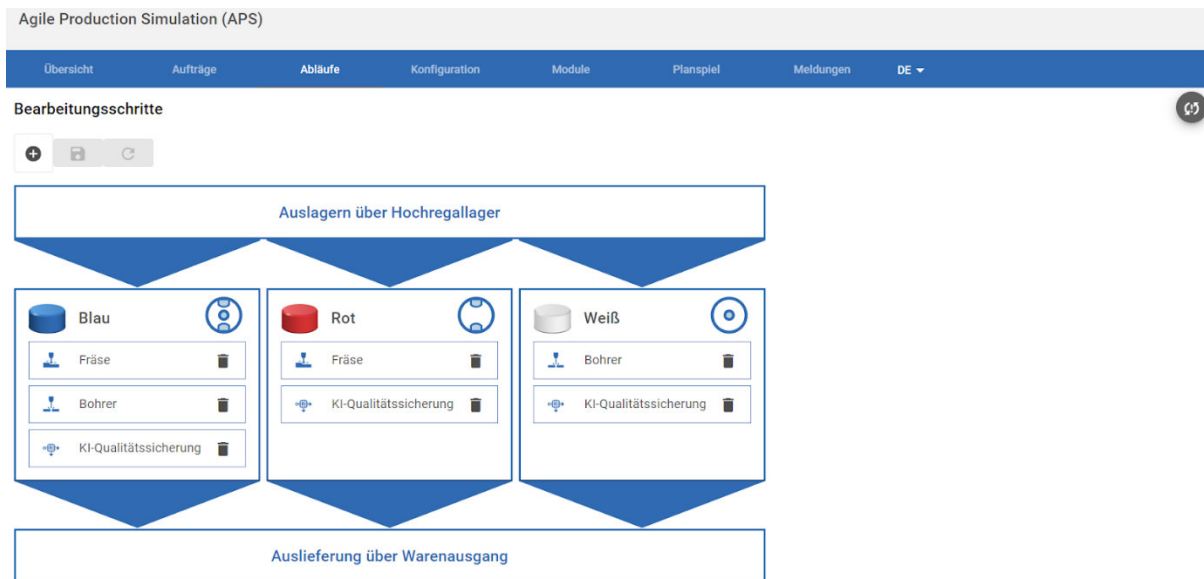

#### 4. Positioning the Automated Guided Vehicle in the APS

In order to determine the initial position of the AGV, place the AGV in front of the incoming/outgoing goods module, with the camera of the AGV pointed toward the module. You can dock the AGV to the module using the “Module” interface you are already familiar with. Click the “Dock to DPS” button to make the AGV start up and dock to the module.

This action is also required after restarting or resetting the APS.

Once the AGV is successfully docked, you can send it to the charging station by clicking the “Charge” button. The AGV should be fully charged before continuing with commissioning.

The charging process will end automatically when the charger detects that the battery is fully charged. Alternatively, you can end the charging process prematurely via the “End charging” button. The AGV will move to a free module to clear the charging station once again.

#### 5. Delivering raw materials

Raw materials are delivered by inserting a workpiece into the incoming goods at the incoming / outgoing goods station, shown here on the left side of the image.



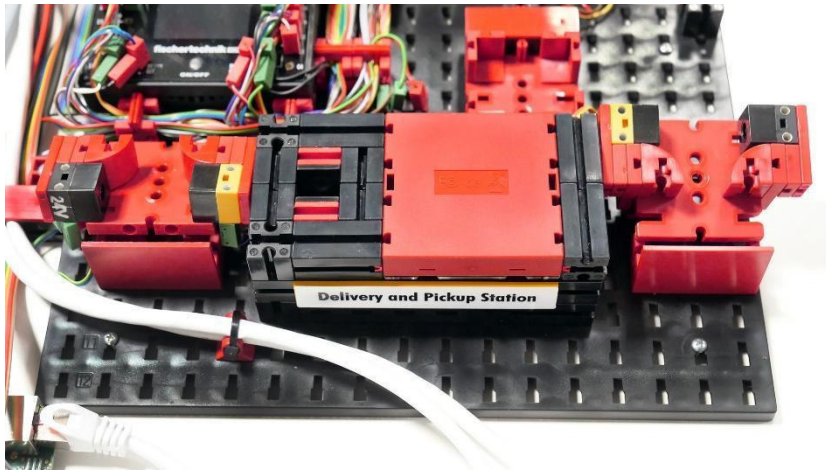

There are three different colors that can be produced by the APS. Stickers are attached for each color that are detected as OK or NOK (not OK) by the quality assurance.

There are 3 IO components:

OK or PASSED indicates that the component is OK.  
 NOK or FAILED indicates that the component is not OK.



3x white with drill hole

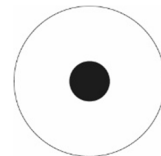

3x red with two milling pockets

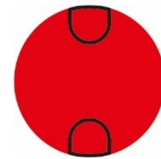

3x blue with two milling pockets and drill hole

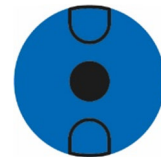

There are 5 NIO components per color:

**White:**



With oval drill hole

With drill hole and one milling pocket

With crack

With one milling pocket

With drill hole and crack

**Red:**

With drill hole and two milling pockets

With drill hole and one milling pocket

With crack

With one milling pocket

With two milling pockets and crack



**Blue:**

With two milling pockets

With drill hole and one milling pocket

With crack

With one milling pocket

With two milling pockets, drill hole and crack

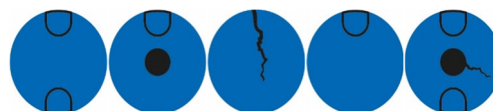

Once the light barrier is interrupted, the module will pick up the workpiece with the gripper and classify it. This includes using the RGB sensor to determine the color and reading out the NFC chip attached inside the workpiece.

We recommend using a blue workpiece with the following print (OK – no error pattern) for initial production.



This workpiece is drilled and milled in the standard configuration, as well as checked for defects in the quality assurance. Therefore, by producing this workpiece you can directly test all assembled modules.

Do not forget to end the charging process for the AGV if it is still in the charging station.



Delivery of raw materials is completed once the workpiece

- has been analyzed by incoming goods. This includes:
  - Determining the color of the workpiece.
  - Write the current storage date on the NFC tag in the workpiece.
- transported by the AGV to the high bay warehouse.
- stored in the high bay warehouse.
- displayed in the “Overview interface as stock.

## 6. Triggering an order

After successfully storing the raw material, it will be available for order.

To do so, switch to the “Overview” user interface. There, you will find a variety of information about the APS, including the stock level, measurement data for the sensor station, the camera image for the module and the order view.

You can click “Order” to trigger the production order, which will move the modules to process the workpiece in sequence according to your configuration, and then remove the workpiece from storage once again.

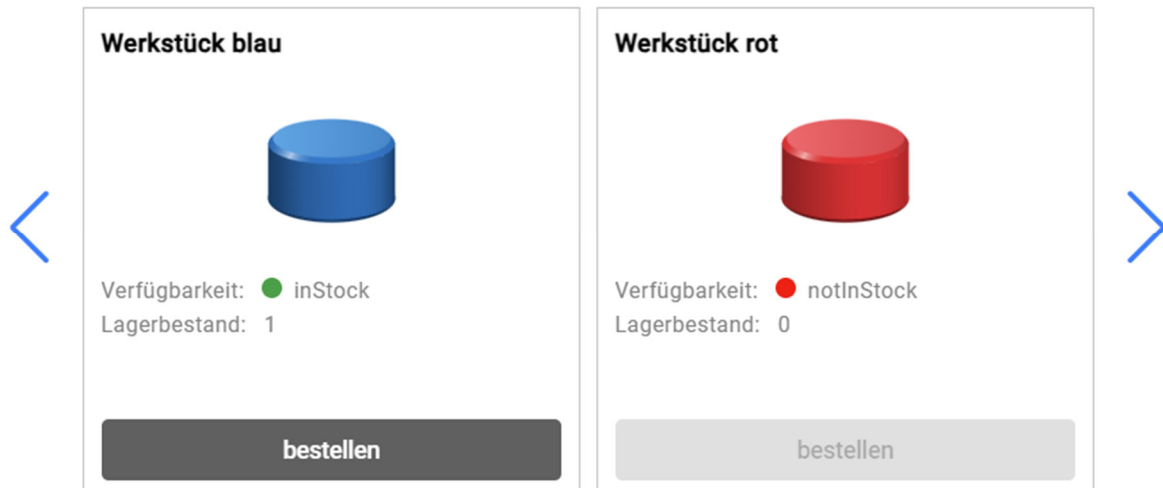

All current production orders are displayed in the “Orders” menu during the APS run time. This includes the following information, among other things:

- Order number (generated automatically by the central controller)
- Order start and current status
- All manufacturing steps required to produce the workpiece.
- The module on which the order is currently being carried out.

Agile Production Simulation (APS)

Übersicht **Aufträge** Abläufe Konfiguration Module Planspiel Meldungen DE

**Laufende Aufträge**

Auftrag	03:48	BLUE	12.11.23, 15:48
---------	-------	------	-----------------

**Fertigungsschritte**

- Fahrerloses Transportsystem > Hochregallager
- Hochregallager : FTS beladen
- Fahrerloses Transportsystem > Fräse
- Fräse : FTS entladen
- Fräse : Fräsen
- Fräse : FTS beladen
- Fahrerloses Transportsystem > Bohrer
- Bohrer : FTS entladen
- Bohrer : Bohren
- Bohrer : FTS beladen
- Fahrerloses Transportsystem > KI-Qualitätssicherung
- KI-Qualitätssicherung : FTS entladen
- KI-Qualitätssicherung : Qualitätsprüfung
- KI-Qualitätssicherung : FTS beladen
- Fahrerloses Transportsystem > Warenein- und -ausgang
- Warenein- und -ausgang : FTS entladen

**Aktueller Fertigungsschritt**

**Auftragsinformationen**

Auftragsnummer	bfe83e5d-d7dd-4a7f-ba34-b43bdf37dee
Auftragsstatus	In Bearbeitung
Bestelldatum	12.11.23, 15:48
Auftragsingang	12.11.23, 15:48
Start der Bearbeitung	12.11.23, 15:48

A detailed list of individual production steps is shown under the “Production steps” heading in the image above. The blue workpiece is

1. Removed from the high bay warehouse.
2. Milled on the milling station.
3. Drilled on the drilling station.
4. Checked for defects at quality assurance.
5. Removed from storage at outgoing goods once the quality inspection has been completed successfully.

Each processing on a module runs according to the same pattern:

1. Workpiece is transported to the module by the AGV and unloaded there.
2. Workpiece is processed, stored or inspected by the module.
3. Workpiece is loaded back on the AGV and transported to the next step.

When the workpiece is delivered to outgoing goods, the first production order is complete. The current order is removed from the view and is available for further analysis under the “Simulation game” menu.

If production is not carried out to the end, there may be different reasons for this:

- The AGV loses the track, for instance due to external influences.
- A model is set to error state, indicated by an error message on the TXT controller of the module or the red LED on incoming / outgoing goods.

Use the Reset button in the interface to set the APS back into an operable state. Existing orders will be deleted so that production can restart with a new status.

The “Simulation game” view contains an analysis of the OEE indicator (Overall Equipment Effectiveness) for all production orders. This applies both to production orders completed in normal APS operations and to simulation games that can be launched in this view.

The simulation game can then be started by completing the following steps:

1. Prepare the APS: To start the simulation game, there must be workpieces in the storage. These can be added by the usual storage process at incoming goods. All modules must also be connected and ready.
2. Configure the simulation game: Additional workpieces from the storage can be added to the simulation game using Add workpiece. The interface will validate the set configuration, so that only valid simulation games can be started.
3. Click “Start simulation game” to create the set configuration in the APS as an order and start production.
4. Analyze the simulation game: After the last production step, the productivity of the APS can be analyzed using the calculated indicator OEE and changes can be made to improve it.

The following formulas are used in the APS simulation game to calculate the indicator OEE:

$$\text{OEE} = \text{Performance} * \text{Availability} * \text{Quality}$$

Example: Performance is 80%, Availability is 100%, and Quality is 67%

$$\text{OEE} = 0.8 * 1.0 * 0.67 = 0.536 = 53.6\%$$

$$\text{Performance} = \text{Total planned production time} / \text{measured production time}$$

Example: A 200 second production time is configured for red and 400 seconds for blue as the planned value. Total production will take 700 seconds to successfully complete both orders.

$$\text{Performance} = (200 + 400) / 700 \sim 0.86$$

**Availability** = Total time from the start of the order to the end / time in production or transportation steps.

Example: Production will start and continue for a total of 100 seconds, followed by 50 seconds of transportation. 200 seconds will pass before the last order is complete.

$$\text{Availability} = 100 + 50 / 200 = 0.75$$

**Quality** = Number of successful orders / total number of orders

Example: 3 orders are included in the simulation game; 1 workpiece is sorted out by quality assurance.

$$\text{Quality} = 2 / 3 \sim 0.67$$

Remarks:

- When calculating availability, small pauses (less than 500ms) between the end of one step and start of the next step are ignored. System-related delays are, therefore, not included in the processing and 100% availability is possible.
- When calculating availability, the start time is the time the "ReceivedAt" order is received after the order starts. The APS assumes that all modules are ready for operation at the start of the simulation game.

# Commissioning with fischertechnik Cloud

Networking the APS with the fischertechnik Cloud makes it possible to control, monitor and optimize production processes via the Internet. Setting up this connection is explained in four steps below.

The fischertechnik Cloud is available at the following URL

<https://www.fischertechnik-cloud.com>

## 1. Connecting the router to an Internet connection

Before the APS can communicate with the cloud, it must be ensured that the local network of the APS is connected to the internet. This is achieved by connecting the router to an external internet source.

Make sure that you are connected to the APS network. Use your browser to navigate to the address <http://192.168.0.1/>. The following login screen for the travel router installed on the APS will appear. You can log in there with the default password "admin1".

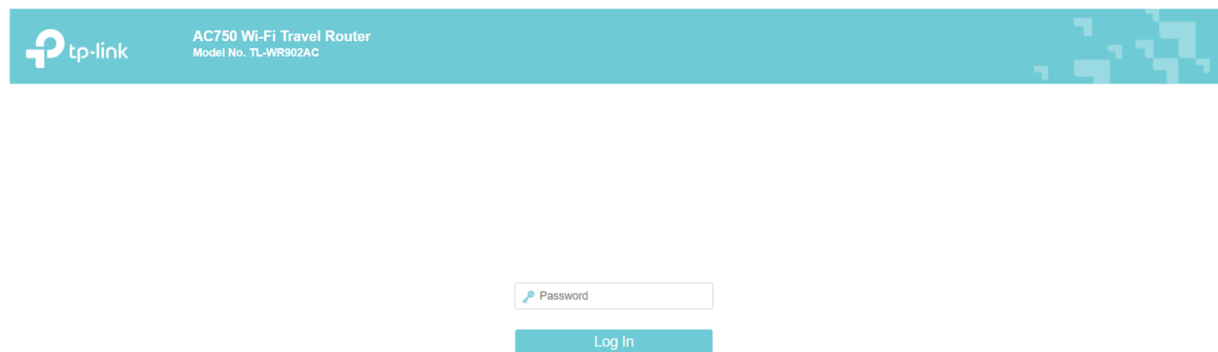

Carry out the "Quick setup"

1. The password for the network should **not be changed**, otherwise it must also be changed on all components of the APS
2. Select "**Dynamic IP**" as an option for the WAN connection
3. The client settings and the wireless password of the external network can be found on the configuration pages of your WLAN access point or requested from your network administrator.
4. Confirm and exit setup
5. Verify the Internet connection by accessing the fischertechnik Cloud from your end device: <https://www.fischertechnik-cloud.com> Make sure that your end device is not connected to any networks other than the APS.

If you require further information, you can find this in the router documentation:

AC750 Wi-Fi Travel Router - Model No. TL-WR902AC



[https://www.tp-link.com/us/user-guides/tl-wr902ac\\_v3/](https://www.tp-link.com/us/user-guides/tl-wr902ac_v3/)

## 2. registration in the fischertechnik Cloud

To be able to use the service, you must register. To do this, go to [www.fischertechnik-cloud.com](http://www.fischertechnik-cloud.com). It is best to use "Firefox" or "Google Chrome" as your Internet browser.

The following screen appears.

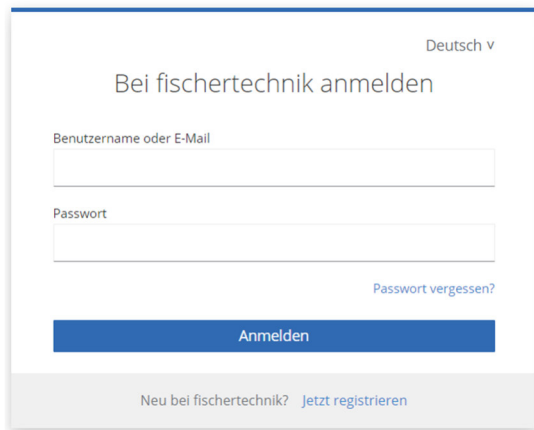

Select "Register now" to create your personal account. Fill in all the fields and confirm your registration by clicking the "Register now" button.

After registering, you must confirm your e-mail address, then you can log in with your user name and password. You can now use your account to access the fischertechnik Cloud. The next step is to connect your APS to your Cloud account so that data can actually be synchronized.

## 3. coupling the APS with the fischertechnik Cloud

On the Incoming/outgoing goods module contains another TXT controller. This is the heart of the connection between the APS and the fischertechnik Cloud and is referred to below as the gateway. After coupling, direct communication with the cloud is possible via this, the controller serves as a gateway between the data transfer within the APS network and the Internet. To set up the connection, the APS program must be closed if it has already been started in a previous step.

Connect the TXT controller to the fischertechnik Cloud using the following menu items on the touchscreen of the TXT 4.0 controller

"Settings - fischertechnik Cloud - New coupling".

If the TXT Controller can establish a connection with the cloud, a QR code and a pairing code will appear. You now have 30 minutes to add the TXT Controller to

your account in the cloud. After this time has elapsed, you must start the pairing process again.

You can scan the QR code, e.g. with the "Quick Scan" app, and you will automatically be directed to the fischertechnik cloud.

Alternatively, you can go to "Settings - Add controller" on the fischertechnik cloud page and enter the pairing code there manually. Here you can enter any name for the TXT controller, e.g. its ID "TXT-7133".

Select the "Agile Production Simulation" module.

If pairing is successful, this is indicated on the display with "Pairing successful!".

Under the "Settings" menu item in the left-hand navigation bar, you will find a list of all controllers linked to your account.

#### **4. triggering the first order process via the cloud**

The interfaces for controlling and monitoring the APS are integrated in the fischertechnik Cloud under the menu item "Agile Production Simulation". You are already familiar with these interfaces from commissioning the APS with the local application, but you can now also use the same actions via fischertechnik Cloud.

## Programming tasks for PLC development

To solve the programming tasks, you will need previous knowledge of the "Structured Text" programming language (ST or SCL) and how to use the TIA Portal development environment.

The programming solutions provided have been created with the TIA Portal V18 for a SIMATIC S7-1200 programmable logic controller with CPU1512SP.

Alternatively, other control systems with the appropriate software can also be used here.

You can find an introduction to programming with the TIA Portal here at SIEMENS, for example:

<https://www.siemens.com/de/de/produkte/automatisierung/systeme/industrie/sps/s7-1200.html>

<https://new.siemens.com/global/de/unternehmen/nachhaltigkeit/ausbildung/sce/learn-lehr-unterlagen/erweiterte-programmierung.html>

Further information including the sample solution can be found at:

<https://github.com/fischertechnik/Agile-Production-Simulation-24V>

## **Task 1: Multiple milling**

Focus: Understanding and adapting the program sequence and loading it onto the PLC.

Objective: Instead of milling the workpiece only once as before, it should now be milled twice. The milling machine stops for one second between the two milling processes.

## **Task 2: Extend OPC UA interface**

Focus: Values permanently defined in the program code can be configured via the OPC UA interface to enable a more flexible response to production scenarios without having to adapt the programming of the PLC.

Objective: The time between milling operations defined in task 1 can now be freely defined via the OPC UA interface.

# Technical documentation

## Technical structure of APS

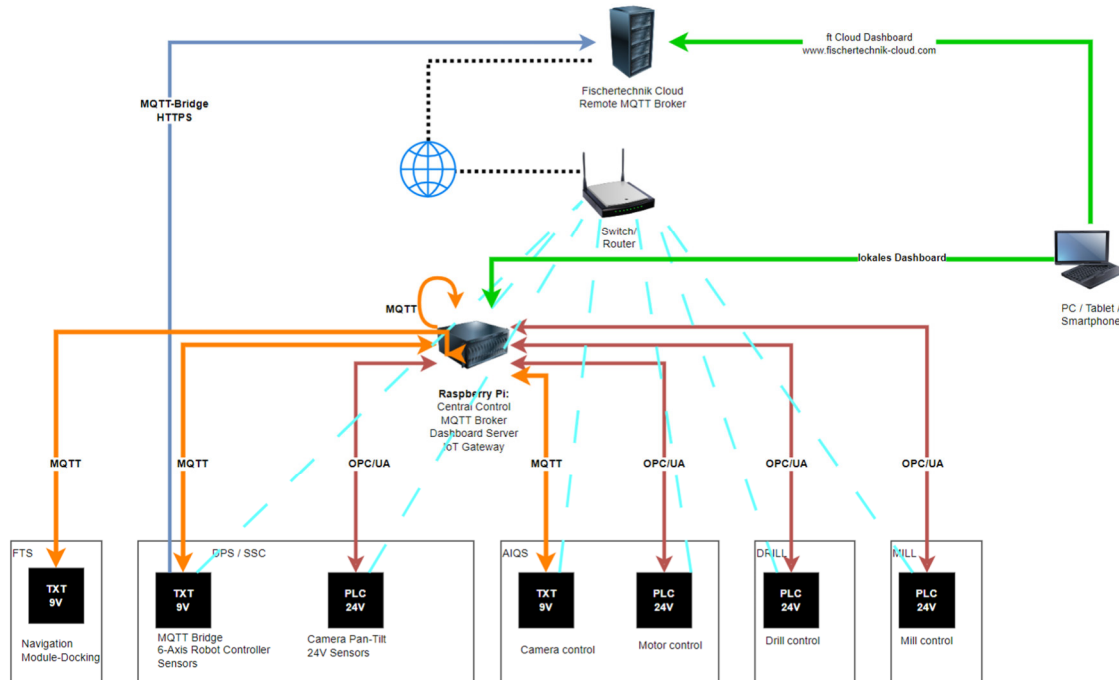

The overall product is made up of six individual modules. This modularity enables flexible configuration and adaptation to specific requirements and processes.

The modules are technically equipped with different controllers. Both the **TXT 4.0 controller** and the **S7-1200 PLC** are used. This variety of controllers allows a wide range of functionalities and the **integration of various technical standards**. The TXT 4.0 controllers communicate with the central controller via MQTT. An individual OPC UA server is started on the PLC in each case.

The **Raspberry Pi** forms the heart of the system. This central unit runs the central control software, which is responsible for managing the individual production orders, among other things. This ensures efficient and centralized control of the entire production process.

An **MQTT broker** and **Node-RED** are also executed on the Raspberry Pi. Node-RED serves as a bridge that realizes the translation from **OPC-UA** to **MQTT**. The MQTT broker is an essential system component that supports a **publish/subscribe architecture**. In this architecture, messages can be published, which can then be retrieved and processed by all authenticated participants in the network.

The network is managed via a tp-link router. This router enables both wired and wireless network connections and thus ensures the **connectivity of all system components**.

A key aim of this setup is to be close to real production environments. Even in reality, it is unlikely that all components will use the same technical standard. This diversity reflects the real conditions in the industry. Particular emphasis is placed on the integration of different technologies and standards in order to create the most efficient and flexible production environment possible.

The APS also relies on **industry-standard communication frameworks**. Various groups are continuously working on cross-manufacturer issues to enable the most effective message transmission for defined modules. Communication with the automated guided vehicle system (AGV) in particular is based on the **VDA5050** standard.

An optional extension offers a connection to the **fischertechnik Cloud**. A gateway on the TXT 4.0 controller of the incoming/outgoing goods department enables this connection. Relevant messages in the local network of the APS are forwarded to the **cloud broker** and processed and displayed by the fischertechnik cloud.